

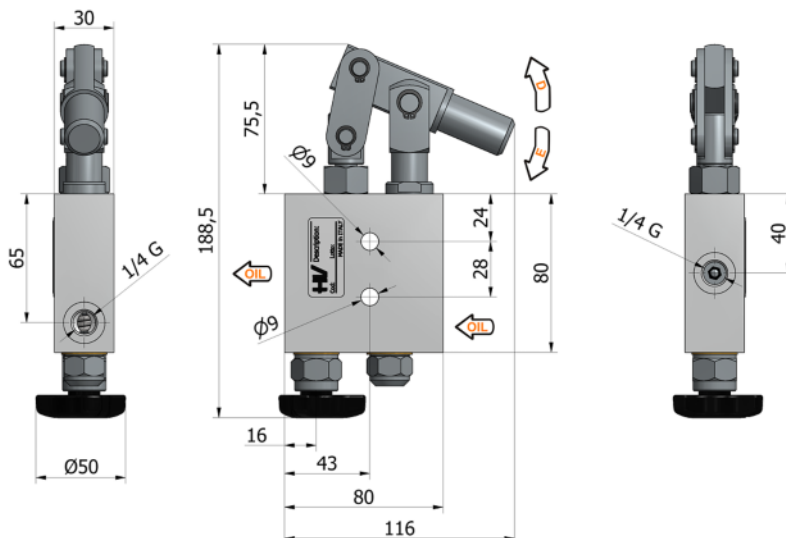

PMSE 2,5 byB

with release hand wheel
with pressure relief valve
single acting hand pump for a single acting cylinder
for fixing to wall

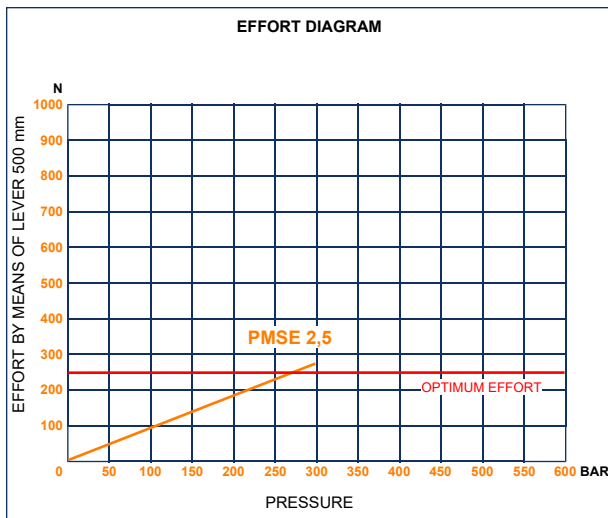
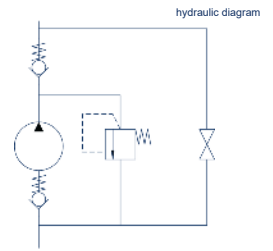

Specifications:

- Aluminum body
- Piston treated with Niploy
- Hold lever of zinc plated steel
- Lever connection of diam. 20
- External parts of zinc plated steel
- Pressure relief valve standard setting of 100 bar

DISPLACEMENT cm ³	A mm	B mm	C mm	D °	E °	ACTUAL DISPLACEMENT cm ³	PRESSURE BAR		MASS KG	CODE
							OPTIMAL	MAX		
2,5	--	--	--	9	24	2,610	270	300	1,200	6064.0002